



BW-100-SL
3 ton Roller



UPPER VALLEY
EQUIPMENT RENTALS

INC
8 BRIDGE ST., W. LEBANON, NH 03784
603-298-8744

\$225 - Day Rental
\$900 - Week/5 days
***delivery not included**

*Pricing subject to change

Overview

Light tandem rollers for soil compaction and asphalt patching. Ideal for footpaths and repair work as well as finishing work in road construction. Compact BOMAG tandem rollers have also acquired an excellent reputation in landscaping.

Specifications

Weights

-operating weight w. ROPS CECE	5,181 lb.
-average static linear load CECE	65.8 lb.
-gross weight	6,173 lb.

Brakes

-service brake	hydrost.
-parking brake	hydromech.

Steering

-steering system	oscil. aric.
-steering method	hydrost.
-steering angle +/-	32 deg.
-oscillating angle	10.0 deg.

Exciter system

-vibrating drum	front/rear
-drive system	hydrost.
-frequency	72 vpm
-amplitude	0.020 in.
-centrifugal force	7,644/1,709 lb.
-sprinkler system	pressure

Dimensions

-working width	39.4 in.
-track radius, inner	100.4 in.

Driving characteristics

-working speed with vibration	0-3.1 mph
-speed	0-5.6 mph
-max gradeability without vibration	40%
-max gradeability with vibration	30%

Drive

-cooling	water
-# of cylinders	3
-speed	2,200 rpm
-electric equipment	12V
-drive system	hydrost.
-driven drum	front/rear

Capacities

-fuel	9.2 gal
-water	43.6 gal.

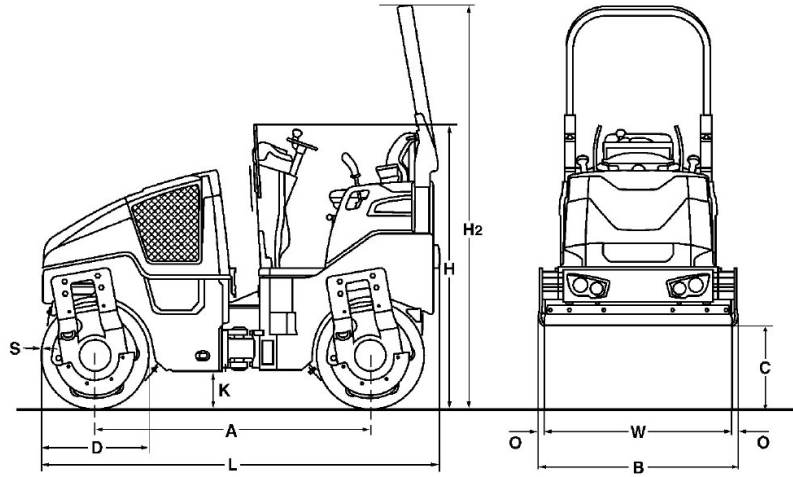

Dimensions in inch

	A	B	C	D	H	H2	K	L	O	S	W
BW 100 SL-5	69.0	42.2	20.6	27.6	71.2	101.1	10.0	99.6	1.4	0.39	39.4

Machine type	Compaction output (cub.yd/h) at recommended soil layer thicknesses		
	Gravel, sand	Mixed soil	Silt, clay
BW 100 SL-5	104.6-189.7	71.9-137.3	49.7-95.5

Machine type	Compaction output (t/h) at different asphalt layer thicknesses		
	0.8-1.6 in	2.4-3.1 in	3.9-4.7 in
BW 100 SL-5	19.6-52.3	52.3-78.5	78.5-130.8