



BW 90 AD-5 1.75 ton Roller



UPPER VALLEY EQUIPMENT RENTALS

INC
8 BRIDGE ST., W. LEBANON, NH 03784
603-298-8744

\$195 - Day Rental
\$780 - Week/5 days
***delivery not included**

*Pricing subject to change

Overview

Light tandem rollers for soil compaction and asphalt patching. Ideal for footpaths and repair work as well as finishing work in road construction. Compact BOMAG tandem rollers have also acquired an excellent reputation in landscaping.

Specifications

Weights

-operating weight CECE	3,527 lb.
-average static linear load CECE	49.8 lb.
-gross weight	4,189 lb.

Brakes

-service brake	hydrost.
-parking brake	hydromech.

Steering

-steering system	oscil. aric.
-steering method	hydrost.
-steering angle +/-	33 deg.
-oscillating angle	8.0 deg.

Exciter system

-vibrating drum	front/rear
-drive system	hydrost.
-frequency	2,520.0/3,780.0 vpm
-amplitude	0.020 in.
-centrifugal force	1,776/3,867 lb.
-sprinkler system	pressure

Dimensions

-working width	35.4 in.
-track radius, inner	79.9 in.

Driving characteristics

-working speed with vibration	0-6.2 mph
-speed	0-6.2 mph
-max gradeability without vibration	40%
-max gradeability with vibration	30%

Drive

-cooling	water
-# of cylinders	3
-speed	3,000 rpm
-electric equipment	12V
-drive system	hydrost.
-driven drum	front/rear

Capacities

-fuel	7.9 gal
-water	26.4 gal.

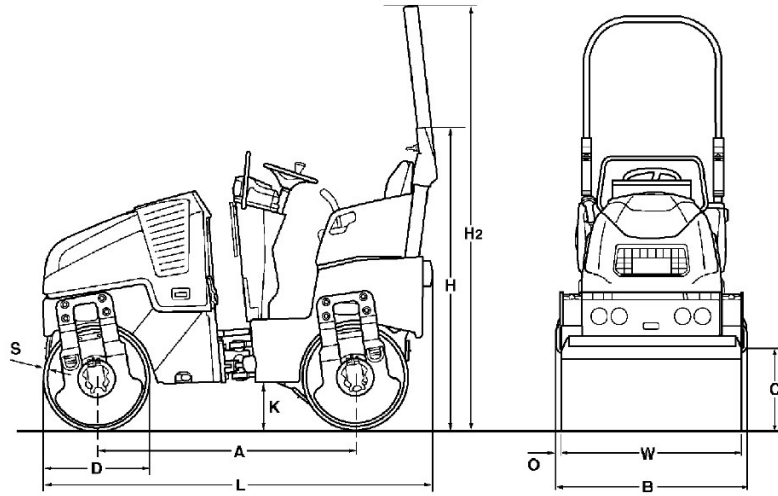

Dimensions in inch

	A	B	C	D	H	H2	K	L	O	S	W
BW 90 AD-5	58.4	37.6	17.0	22.8	64.1	90.7	10.0	86.4	1.1	0.47	35.4

Machine type	Compaction output (cub.yd/h) at recommended soil layer thicknesses		
	Gravel, sand	Mixed soil	Silt, clay
BW 90 AD-5	91.6-157.0	58.9-117.7	45.8-91.6

Machine type	Compaction output (t/h) at different asphalt layer thicknesses		
	0.8-1.6 in	2.4-3.1 in	3.9-5.5 in
BW 90 AD-5	19.6-39.2	39.2-65.4	52.3-104.6