



BOMAG
FAYAT GROUP

**BW-900-50
Roller**



**UPPER VALLEY
EQUIPMENT RENTALS**

INC
8 BRIDGE ST., W. LEBANON, NH 03784
603-298-8744

\$195 - Day Rental
\$780 - Week/5 days
***delivery not included**

*Pricing subject to change

Overview

The 900-50 is a light tandem roller perfect for soil compaction and asphalt patching. Light tandem rollers are ideal for footpaths and repair work as well as finishing work in road construction. Compact BOMAG tandem rollers have also acquired an excellent reputation in soil construction.

Specifications

Weights

- operating weight CECE **2,646 lb.**
- average axel load CECE **1,321 lb.**
- average static linear load CECE **37.3 lb./in.**

Brakes

- service brake **hydrost.**
- parking brake **mech.**

Steering

- steering system **oscil. aric.**
- steering method **hydrost.**
- steering angle +/- **33 deg.**
- oscillating angle **6.0 deg.**

Exciter system

- vibrating drum **front**
- drive system **hydrost.**
- frequency **70 vpm**
- amplitude **0.020 in.**
- centrifugal force **3,372 lb.**
- sprinkler system **pressure**

Dimensions

- working width **35.4 in.**
- track radius, inner **64.8 in.**

Driving characteristics

- working speed with vibration **0-2.5 mph**
- max travel speed **0-5.5 mph**
- max gradeability without vibration **40%**
- max gradeability with vibration **30%**

Drive

- cooling **air**
- # of cylinders **2**
- speed **3,300 rpm**
- electric equipment **12V**
- drive system **hydrost.**
- driven drum **2**

Capacities

- fuel **7.1 gal**
- water **36.2 gal.**

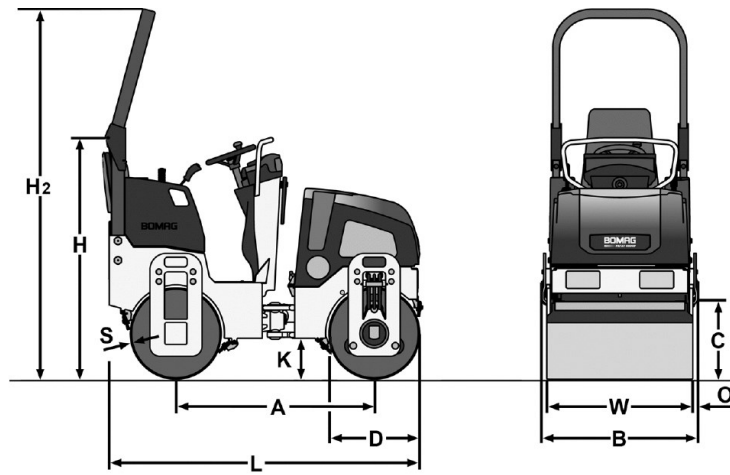

Dimensions in inch

	A	B	C	D	H	H2	K	L	O	S	W
BW 900-50	48.1	37.8	17.7	22.0	68.0	90.2	9.8	77.4	1.2	0.31	35.4

Machine type	Compaction output (cub.yd/h) at recommended soil layer thicknesses		
	Gravel, sand	Mixed soil	Silt, clay
BW 900-50	65.4-130.8	45.8-91.6	39.2-71.9

Machine type	Compaction output (t/h) at different asphalt layer thicknesses		
	2-4 in	6-8 in	10-14 in
BW 900-50	13.1-32.7	26.2-52.3	39.2-78.5